

FIREFIGHTING MODULE

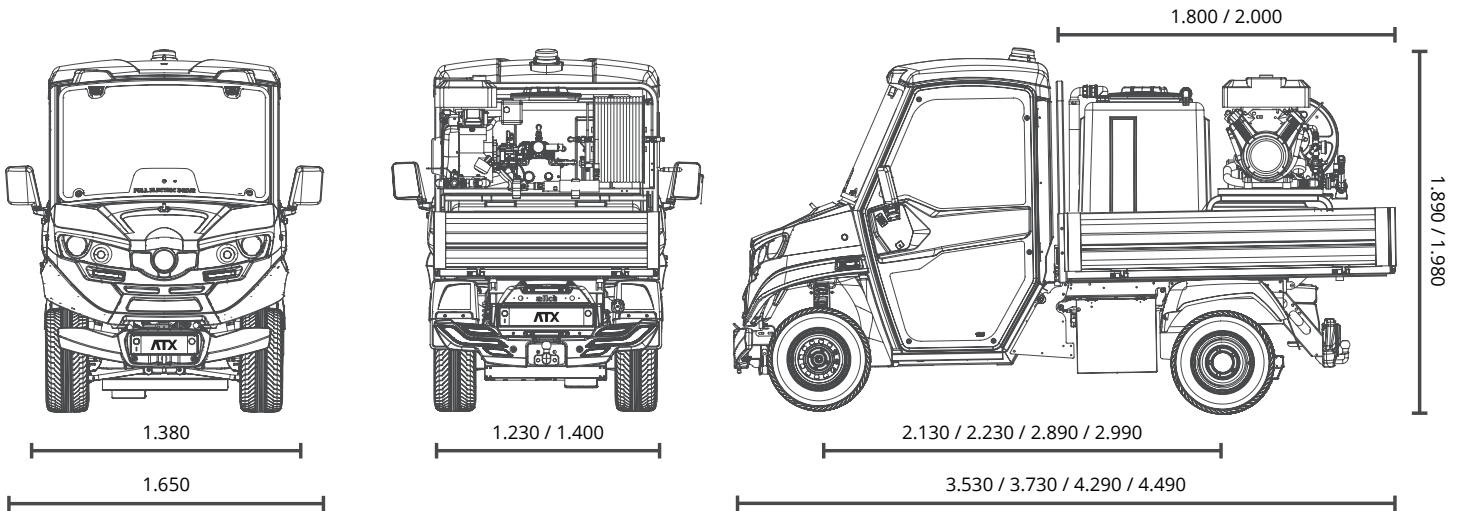

FF1 / FF2



In situations as fires in which time is precious, having a ready-for-use vehicle in case of necessity allows to save human lives and to delimit material damages. This firefighter module can be installed in ALKE' electric utility vehicles ATX 330E/ED/EH/EDH and ATX 340E/ED/EH/EDH model as

well, has the European N1 WLTP type approval for use on public roads and it is composed by a tank of 600 liters provided with fire hose reel and 50 m hose pipe with fire prevention spray gun. Rapid and easy to use even for just one operator, it is the solution directly on the spot to intervene as fast as possible in case of fire.

compatible models	ATX330 E/ED/EH/EDH ATX340 E/ED/EH/EDH	
N1 road homologation	•	
model ATX	length	height
ATX 330E [mm]	3.530 ⁽¹⁾ / 3.730 ⁽²⁾	1.890 (with standard tyres)
ATX 330ED [mm]	4.290 ⁽¹⁾ / 4.490 ⁽²⁾	
ATX 330EH [mm]	3.530 ⁽¹⁾ / 3.730 ⁽²⁾	1.980 (with standard tyres and flashing LED)
ATX 330EDH [mm]	4.290 ⁽¹⁾ / 4.490 ⁽²⁾	
ATX 340E [mm]	3.530 ⁽¹⁾ / 3.730 ⁽²⁾	1.380 / 1.650 (with wing mirrors closed / open)
ATX 340ED [mm]	4.290 ⁽¹⁾ / 4.490 ⁽²⁾	
ATX 340EH [mm]	3.530 ⁽¹⁾ / 3.730 ⁽²⁾	
ATX 340EDH [mm]	4.290 ⁽¹⁾ / 4.490 ⁽²⁾	
width of vehicle (with wing mirrors closed / open)	[mm]	1.380 / 1.650
loading capacity of vehicle	is given by the load capacity (chassis) of the model on which is mounted the module less the weight of the module and optionals/accessories	

firefighting module

module: weight		
vehicle's weight: empty weight (chassis) of the model on which is mounted the module plus the weight of the module itself and optionals/accessories	[kg]	140
removable module		•
module's structure: reinforced fireproof fiberglass		
tank capacity	[L]	600
two cylinder petrol motor pump with 14 hp and electric start		
piston pump capacity		42 liters at 100 bar
hose reel		•
with manual rewinding complete with fireproof R1 50 meters pipe with gun with full jet and atomized switch		
aspiration kit with filter		•

• as standard Δ optional ! compatible but not type-approved for road circulation
— not available ⁽¹⁾ vehicle with standard wheelbase ⁽²⁾ vehicle with long wheelbase



NOTE

This module is powered by the battery of the vehicle therefore can affect the autonomy of the vehicle itself. **For all the other data** refer to the technical specs of the model on which is fitted the module. **The technical specifications,** design and performance of the products listed in this technical sheet are indicative and may undergo modifications without forewarning.



Via Cile, 5
35127 Padua | Italy



+39.049.8702400
+39.049.761208



info@alke.com

WWW

www.alke.com



© 2021 Alkè

Rev. 210114



ISO 9001:2015 - BN17607/17301
ISO 14001:2015 - BN17607/17302
OHSAS 18001:2007 - BN17607/17303

• as standard Δ optional ! compatible but not type-approved for road circulation
— not available ⁽¹⁾ vehicle with standard wheelbase ⁽²⁾ vehicle with long wheelbase

The technical specifications, design and performance levels indicated in this technical data sheet are by way of example only and may be subject to modifications without prior notice.